

Fiber Coupled Acousto-Optic Modulator 1550nm 200MHz

Part No.: AOM-1550-200M-05-A-G3-PM1550-1-1-1-FA

◆ Specification

Parameter	Unit	Min.	Max.	Typical
Interaction Material		-	-	Tellurium dioxide
Signal Wavelength (λ_c)	nm	1520	1580	1550
Operating Wavelength Range	nm	-	-	± 30
Frequency	MHz	-	-	200
Ultrasonic Velocity	m/s	-	-	4200
Insertion Loss	dB	-	5.0	4.5
Extinction Ratio (Turn On / Off)	dB	60	-	-
Polarization Extinction Ratio	dB	18	-	-
Rise-Time/Fall-Time	ns	-	-	10
Return Loss	dB	40	-	-
Voltage Standing Wave Ratio (VSWR)	/	-	1.2:1	-
Average Optical Power	W	-	0.5	-
Peak Optical Power (Pulse)	kW	-	1	-
Input impedance	Ω	-	-	50
RF Power	W	-	-	3.0
Device Interface		-	-	SMA
Fiber Type	/	-	-	PM1550
Fiber Length	m	-	-	1
Fiber Connector	/	-	-	FC/APC
Operating Temperature	$^{\circ}\text{C}$	-	-	-20 ~ +60
Storage Temperature	$^{\circ}\text{C}$	-	-	-30 ~ +70

*IL is 0.2-0.3dB higher, RL is 5 dB lower, and ER is 2 dB lower for each connector added. Connector key is aligned to slow axis.

◆ AOM Package Dimensions

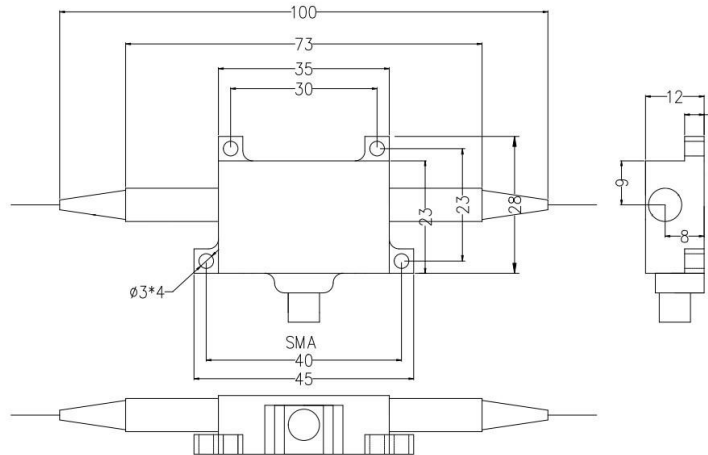

◆ RF Driver Package Dimensions

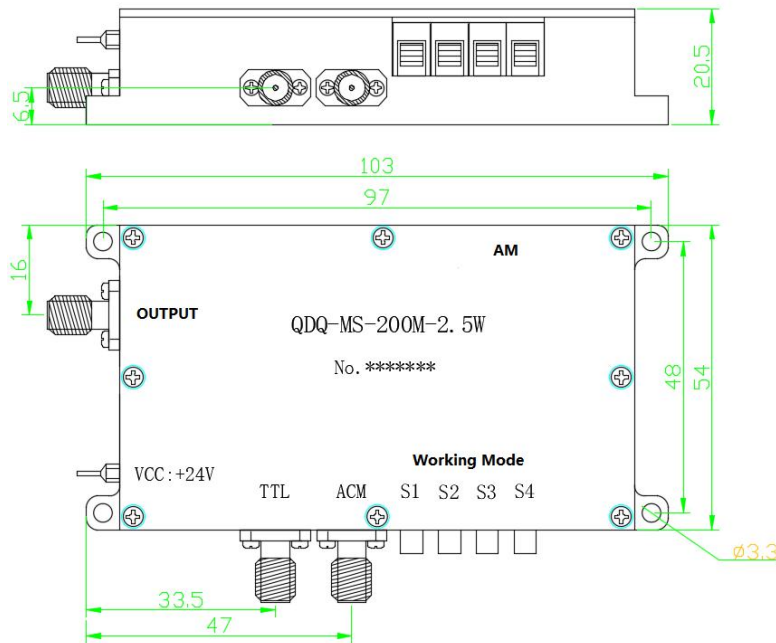

◆ Ordering Information

AOM-①-②-③-④-⑤-⑥-⑦-⑧-⑨-⑩

1-Signal Wavelength	2-Frequency	3-Optical Power	4-Function	5-Package Dimension
1064 - 1064nm	200M - 200MHz	05 - 500mW	S - Frequency Shifting (Up)	C1 - 60*25*12(mm)
1550 - 1550nm	100M - 100 MHz	10 - 1W	A - Amplitude Modulation	G3 - 35*28*12(mm)
1310 - 1310nm	80M - 80MHz	30 - 3 W	SD - Frequency Shifting (Down)	G6 - 67*23*15(mm)
6-Fiber Type	7-Pigtail Length	8-Fiber Jacket	9-Jacket Length	10-Connector
PM980 - PM980	1 - 1M	0 - Bare Fiber	0 - No Jacket	FA - FC/APC
PM1550 - PM1550	1.5 - 1.5M	1-900 μ m Loose Tube	1 - 1M	FU - FC/UPC
SMF28e - SMF28e	S - Specify		S - Specify	N - NO Connector